



馨源电子

公司介绍

宁波

深圳

广州

目录

CONTENTS

01 公司简介

02 产品介绍

03 品牌客户

04 企业环境

05 未来愿景

1

公司介绍



大事记



1980年

为日立电视机国产化配套，批量供应RH系列合金型温度保险丝



1985年

为三菱国产化研制冰箱用温度保险丝，成为上菱、华菱唯一指定RY系列有机物型温度保险丝供应商



1993年

获得中国长城安全认证证书



1997年

作为国家标准起草工作组成员参与《热熔断体的要求和应用导则》
(GB9816-1998) 国家标准起草制定工作化



2002年

获得TUV认证
通过ISO9001:2000版质量管理体系认证



2003年

获得3C认证证书

大事记



2007年

获得CB认证证书



2010年

宁波馨源电子制造中心成立



2011年

通过ISO9001:2008版质量管理体系认证
第一条自动生产线投入运营



2012年

第二、三条自动生产线投入运营



2014年

德国TUV目击实验室资质通过
美国UL目击实验室资质通过
第四条自动生产线投入运营



2017年

全年累计销售RY系列保险丝1亿只，RH系列温度保险丝4000万只

大事记



2018年

德国TUV目击实验室升级为CBTL目击实验室



2019年

第五条自动生产线投入运营，RY系列保险丝销量突破1.5亿只
馨源（深圳）销售公司成立



2020年

健精智能正式开启精益工厂规划项目
第六条自动生产线投入运营



2021年

广州南沙馨源电子有限公司 成立



馨源电子

WPS OFFICE

深圳馨源：

专业的研发与销售团队，满足客户一站式采购需求，提高客户采购工作效率。公司秉承“质量第一、客户至上、开服务快捷、开拓创新”的企业宗旨，力争成为每个客户心中最优质的供应商。



宁波/上海馨源：

40年专业研发与制造的国内知名品牌，国内外知名品牌客户指定优选供应商，力争做“中国最专业的热熔断体制造厂商”，让世界爱上中国造。



广州馨源：

家电线束、设备线束、汽车线束，各种排线、电子连接线 专业制造商；NTC温度传感器、PT100/PT1000温度传感器 专业制造商。

2

产品介绍



产品目录

01

温度保险丝

02

温度传感器

03

电子线束

04

铂电阻芯片

05

温控开关

01

温度保险丝



合金型温度保险丝 Alloy Type Thermal Cutoffs

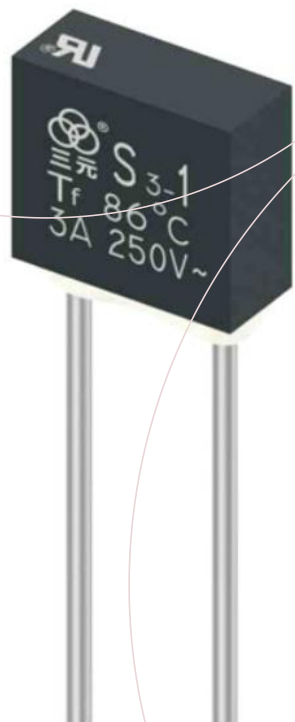

S系列 方块型

类型 type	安培数 current	温度范围temp.range	运用范围 application	备注remark
常规 normal	1A-5A	86°C-150°C	线圈、元器件、 电热、coil, component,h eating, PCB	主力产品key products

熔断前



熔断后



合金/方块型 S系列 应用范围

合金型 S系列温度保险丝主要应用于：排插、开关控制板、电机、马达、电源控制板、热水器、LED灯、卤素灯、烤箱等领域。

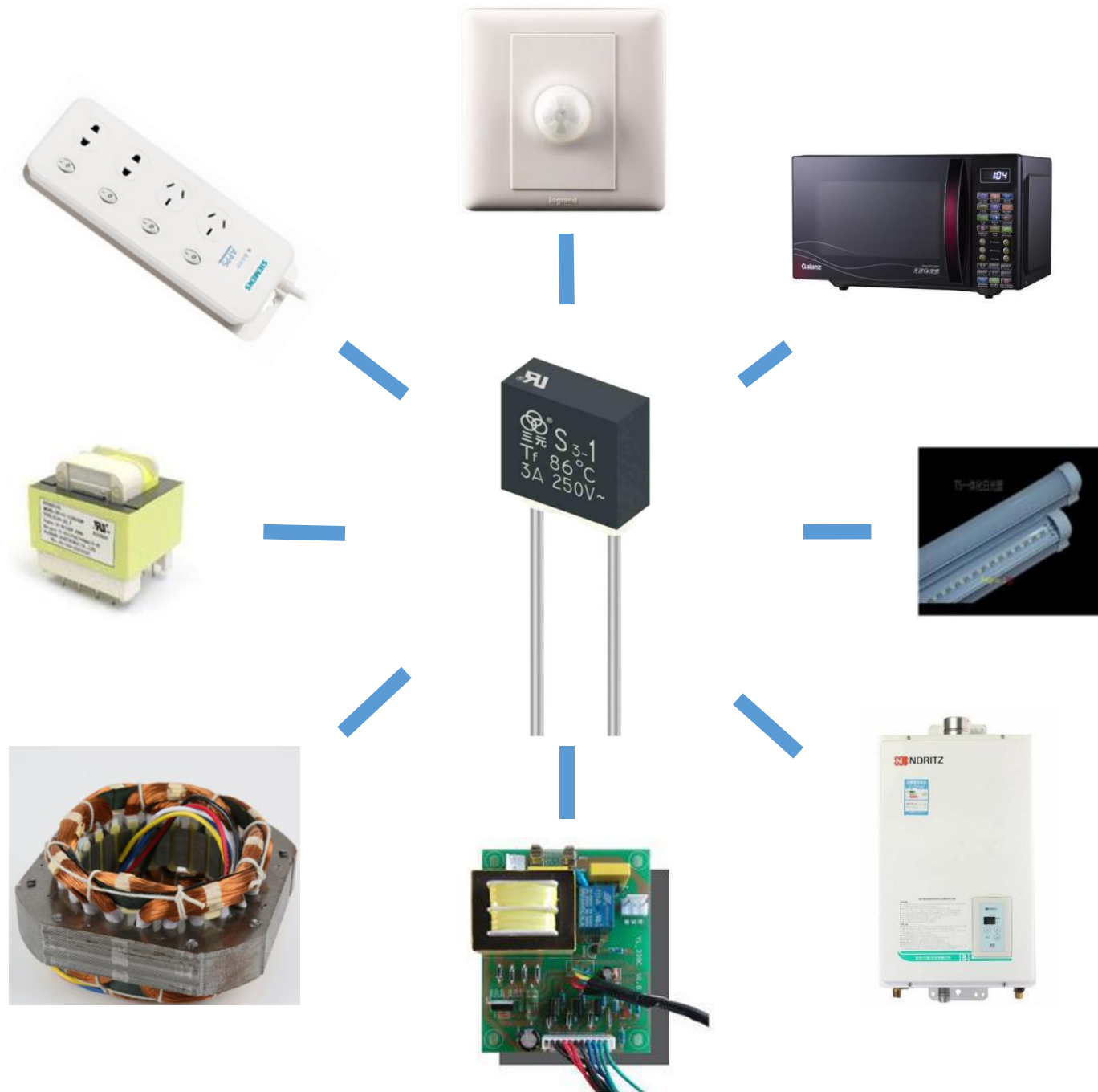

合金型温度保险丝 Alloy Type Thermal Cutoffs



Y系列 瓷管型

类型 type	安培数 current	温度范围temp.range	运用范围 application	备注 remark
常规 normal	1A-5A	86°C-150°C	线圈、元件、电热、 coil, component, heating,	主力产品 key products
RH	10A	150°C-320°C	NEW!	NEW!

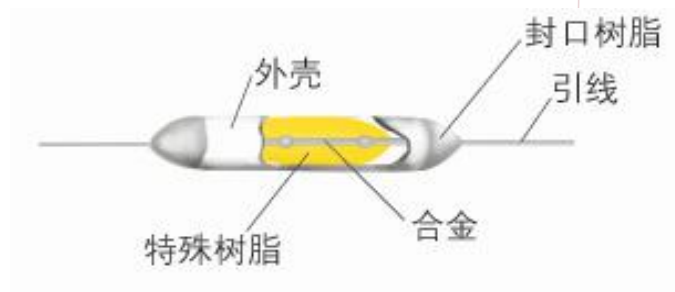

熔断前

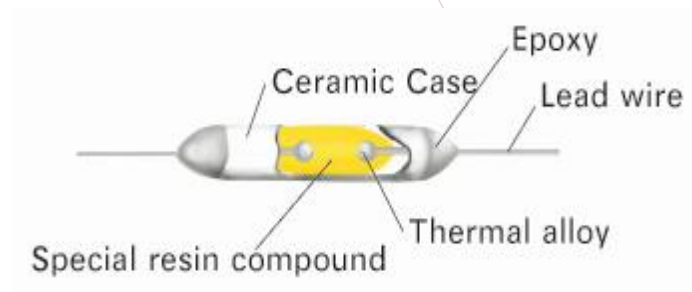

熔断后

合金/瓷管型 Y系列 应用范围

RY有机物系列温度保险丝主要应用于：电热毯控制开关、机器人控制板、打印机控制板、洁面仪、电发钳、电吹风、电机、马达、排插等领域。

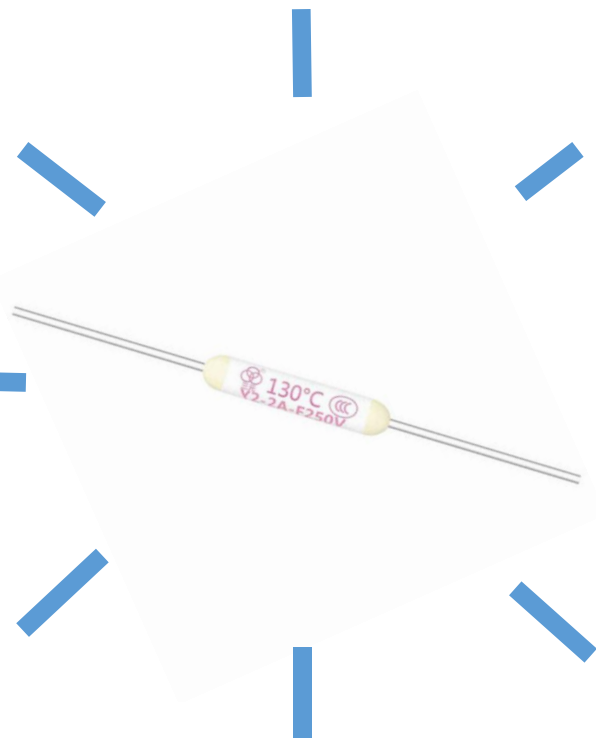
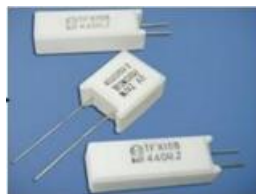

有机物型温度保险丝 pellet Type Thermal Cutoffs



RY系列 有机物型

类型 type	安培数current	温度范围 temp.range	运用范围 application	备注remark
RY	10A/15A/16A 125V/250V	65°C-257°C	家用电器	主力产品 key products
XF	10A/250V			
XFG	15A/125V			
XFH	16A/250V			NEW!
高温 high temp.	10A/250V	>260°C		NEW!
编带 tape & reeled	略NA		自动化工艺下的 各种运用all kind of application under automatic technique	NEW!

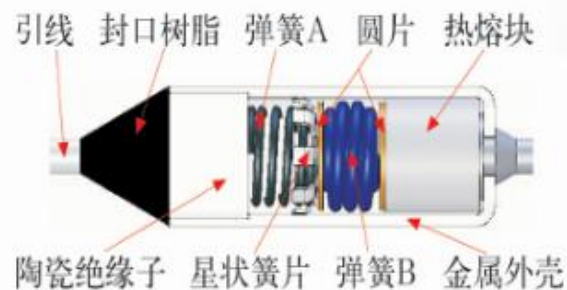

熔断前

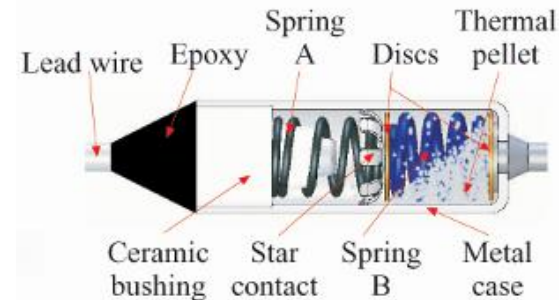

熔断后

有机物型 RY系列 应用范围

RY有机物系列温度保险丝主要应用于：空调、冰箱、洗衣机、取暖器、电吹风、电压力锅、咖啡机、电熨斗、智能马桶、电热水器、空气炸锅、烤箱、汽车加热座椅等领域。



合金型温度保险丝 Alloy Type Thermal Cutoffs



RH series TCO

类型 type	安培数current	温度范围 temp.range	运用范围 application	备注remark
BF	10A/250V	73°C-240°C	电热、线圈、 元器件、 SPD、 PCB,heating, coil,compone nt	主力产品 key products
BF-I	16A/125V			
BFX	16A/250V			
RY	10A/250V	>240°C	自动化工艺下的 各种运用all kind of application under automatic technique	NEW!
高温 high temp.	10A/250V			NEW!
编带 tape & reeled	略NA			NEW!

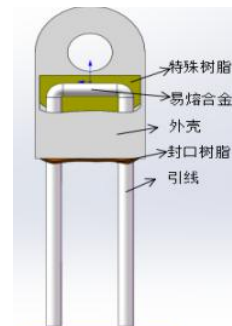

before

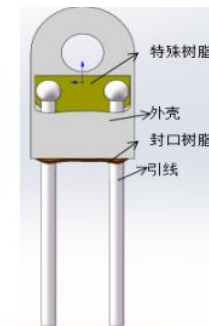

after

合金/瓷扁型 RH系列 应用范围

RH合金型系列温度保险丝主要应用于：厨房料理 豆浆机、破壁机等领域。

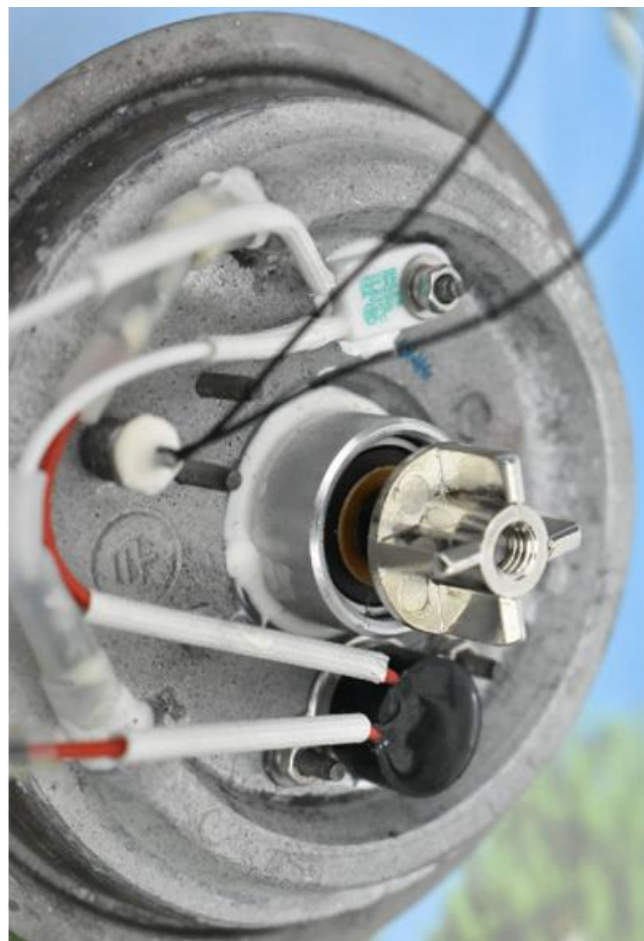

02

温度传感器



定制 NTC温度传感器

应用领域

燃气灶、电烤盘、电磁炉、食物料理机、电熨斗、汽车电子、制冷设备、智能马桶、水处理设备、壁挂炉热水器、咖啡机、微波炉、电烤箱、电饭煲等领域。

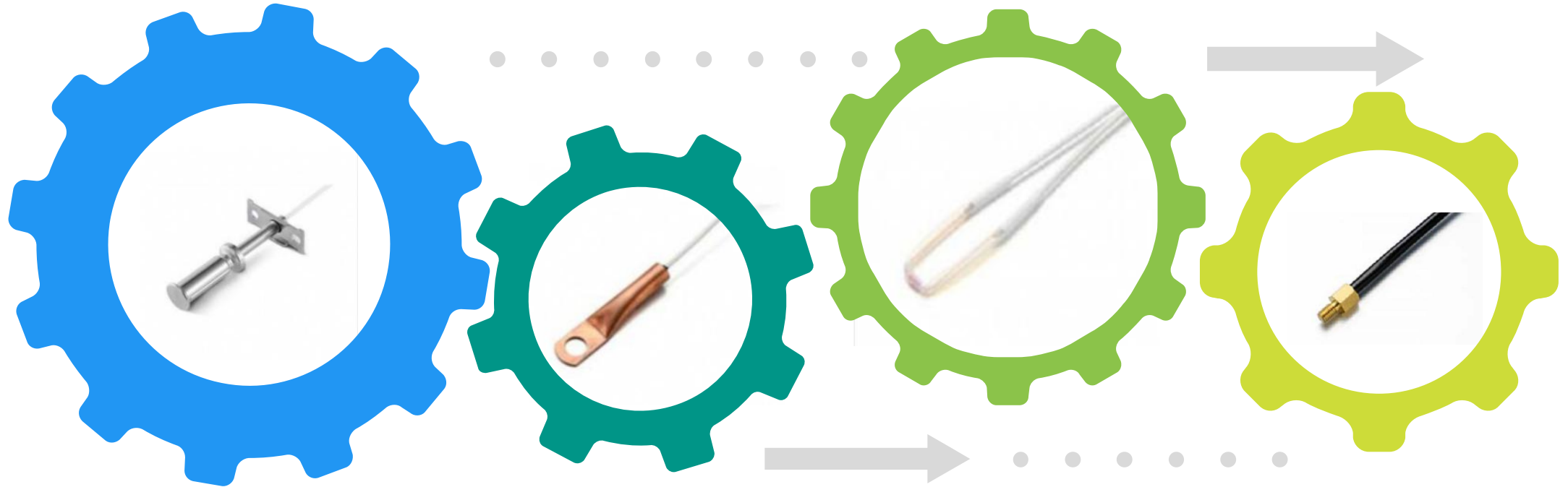

定制 PT100/PT1000温度传感器

应用领域

电机绕组及变压器线圈、新能源电池电机绕组线圈、轴承测温、仪器仪表等领域。

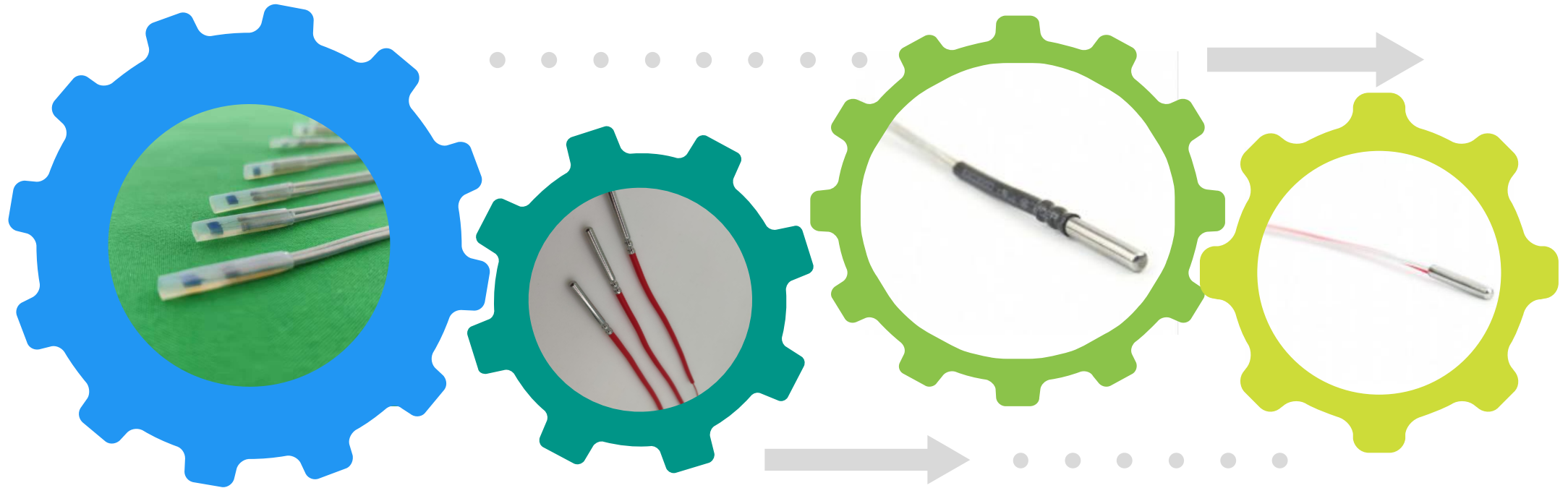

03

电子线束



定制 电子连接线束

应用领域

家电线束、仪器/仪表线束、设备线束、汽车线束等领域。

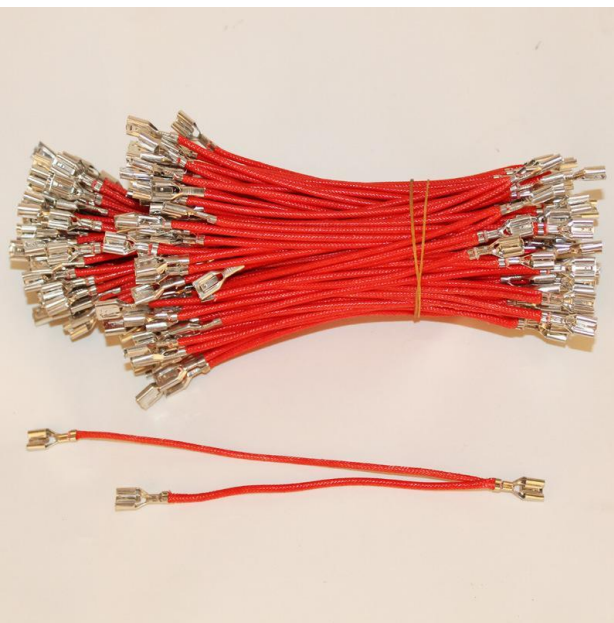

家电线束

非标定制



仪器线束

非标定制



汽车线束

非标定制

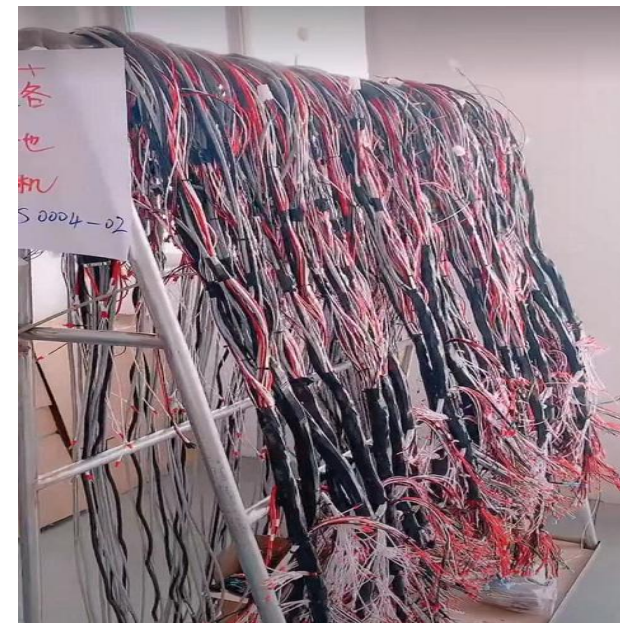

设备线束

非标定制

04

铂电阻芯片



关于贺利氏

德国贺利氏 Heraeus 品牌介绍：德国贺利氏控股集团（Heraeus Holding）是一家活跃于全球的贵金属和科技集团公司，创建于1851年，总部设在德国哈瑙市，核心业务包括贵金属、传感器、生物材料与医用产品、齿科产品、石英玻璃和特种光源等。贺利氏控股集团拥有超过155年的家族经营历史，在全球贵金属和材料科技领域处于领先地位。公司下设五大事业部，在全球设有25个研发中心，拥有110多家分公司和12300余名员工。

高精度的测量是许多关键技术的基础，也是一些有效技术方案的前提。铂电阻温度传感器具有稳定性高，重复性好以及反应时间快等特性。贺利氏先进传感器技术可提供具有不同电阻温度系数（TCR）的种类繁多的铂电阻产品。

铂类薄膜技术的应用范围要远远超出现在大家所熟知的温度传感器。通过将传感器，加热器，电极及其他结构集成到同一基板上，我们可以得到创新型的多功能的芯片产品。

在过去100多年间，为了满足客户的目标，贺利氏先进传感器技术一直持续不断的开发着各种创新型的方案。



位于Kleinostheim的工厂。

贺利氏一级经销

贺利氏中国法务部编章，不得用于非贺利氏业务或私人用途

经销协议

协议编号:

签署日期: 2020年4月30日

供应商 (甲方): 上海贺利氏工业技术材料有限公司

住所: 上海市闵行区颛桥镇南汇路1111号

邮编:

电话:

传真:

经销商 (乙方): 睿源 (深圳) 电子有限公司

住所: 深圳市龙华区龙华街道清华社区龙观东路57号 尚美时代 6层618

邮编: 518102

电话: 0755-2717819

传真: 0755-22717819

甲乙双方经平等、充分协商, 签订以下协议:

1. 经销产品及经销区域

甲方根据本协议条款条件指定乙方在以下规定经销区域内为甲方下述产品的非独家经销商

1.1 经销产品: [温度传感元件和温度传感器] (下文统称“产品”);

1.2 经销区域: [中国大陆] (下文统称“经销区域”);

1.3 如果经销商希望将产品售至经销区域以外的, 接受经销区域之外的订单或参加经销区域之外的投标, 或者在经销区域外对产品进行广告宣传或推销行为, 每次均必须取得供应商的事先书面同意。

1.4 供应商至少提前三个月通知经销商单独生产定制的产品, 标准产品可随时停产, 无需事先通知经销商, 供应商行使上述权利的, 不会导致供应商对经销商承担任何责任。

1.5 非独家性: 双方特此声明, 经销商在本协议项下的经销权不具有排他性, 供应商有权在经销区域内指定产品的其他非独家经销商, 也有权直接在经销区域内进行销售, 供应商无义务向经销商提供其他经销商的信息。

2. 期限

2.1 本协议有效期为从 2020年4月1日 至 2021年3月31日 止, 在本协议期满后, 双方可以书面协议的方式延续本协议期限。

3. 订购流程、价格与付款

3.1 订购单及其确认流程:

贺利氏中国法务部编章, 不得用于非贺利氏业务或私人用途

如致供应商:

上海贺利氏工业技术材料有限公司

联系人:

地址:

传真号:

如致经销商:

睿源 (深圳) 电子有限公司

联系人: 胡志恒

地址: 深圳市龙华区龙华街道清华社区龙观东路57号 尚美时代 6层618

传真号: 0755-22717819

15.8 本协议经双方授权代表签字、盖章后生效, 原件一式二份, 双方各执一份。

15.9 贺利氏行为准则规定了贺利氏员工从事合法及负责行为的原则, 具有约束力, 经销商承诺遵守所有具有法律效力的法规和规定, 特别是关于公平竞争、进出口禁令、海关税收以及环境保护的法令, 不参与任何商业贿赂行为, 向其员工提供合理待遇, 合理的工作时间、安全生产和无歧视工作环境。此外经销商应当与供应商签订贺利氏合规协议书 (附件5), 并作为本协议不可分割的一部分。

供应商 (甲方):

上海贺利氏工业技术材料有限公司

开户行:

银行账户:

纳税号:

公章:

法定或授权代表:

[姓名, 职位]

经销商 (乙方):

睿源 (深圳) 电子有限公司

开户行: 招商银行股份有限公司深圳龙华支行

银行账户: 75504258810401

纳税号: 9440700MASFG1R2R3

公章:

法定或授权代表: (姓名)

[姓名, 职位] 法人

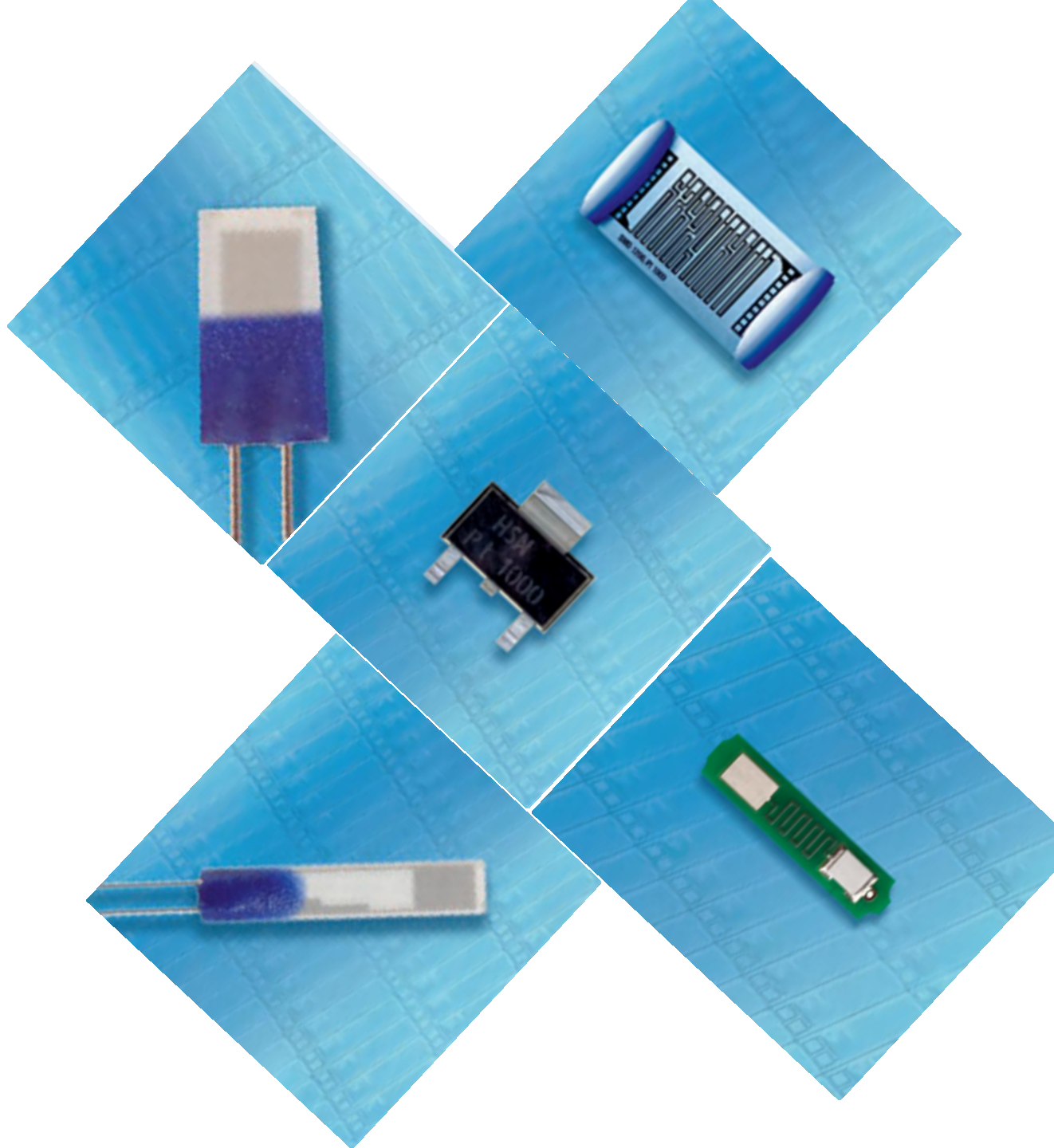

05

温控开关



结构及应用 Structions and applications

KSD系列温度控制器，采用0.5英寸双金属片，性能可靠，结构紧凑，功能齐全，瞬动式双金属片采用独特设计，能提供高速的触点断开。

Φ0.5 inch snap action bimetal disc is the key part of KSD thermostat, which is of reliable performance, compact structure and full function.

尺寸 Dimension

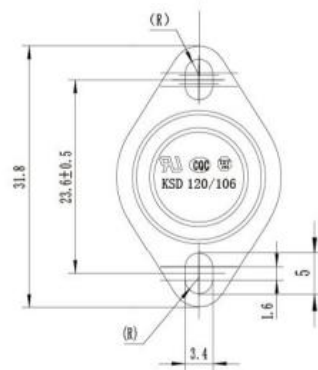
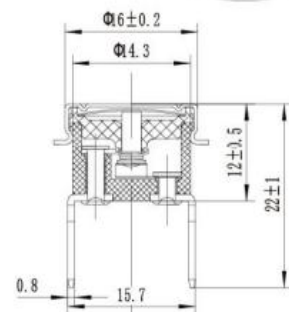
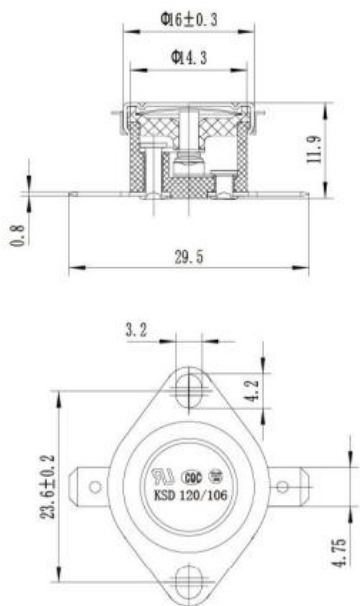
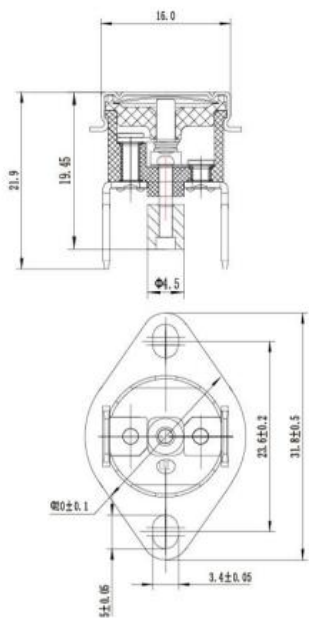

技术参数 Technical Parameter

触点容量: AC120 15A; AC250 10A(UL)
AC250 16A (TUV、CQC)

使用寿命: 10万次

触点形式: 常开、常闭两种形式

复位形式:

自动复位——随着温度的升高，
内部触点自动断开或自动闭合。

手动复位——当温度升高时，触点会自动断开；
当控制器温度冷却后，必须通过手动按键
才能使触点复位而再次闭合。

contact capacity
cycle life

normally status: normally open and normally close

reset type: automatic reset while temperature is ramping up
(automatic open and close)

manual reset: two contacts open automatically when the the
bimetal disc reaches its maximum temperature

After the device breaks the circuit, the system cools and
manual reset is needed to allowing power to be restored to the
circuit.

产品分析图 Components

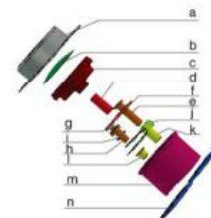

- a. 外罩 outer housing
- b. 双片 bimetal disc
- c. 垫圈 gasket
- d. 顶杆 mandril
- e. 铆钉 clinch bolt
- f. 静触点 stationary piece
- g. 静触点 fixed contact
- h. 铆钉 clinch bolt
- i. 动触点 movable contact
- j. 动触点 movable contact-piece
- k. 空心铆钉 hollow clinch bolt
- l. 空心铆钉 hollow clinch bolt
- m. 底座 Base
- n. 接插片 Inserting disk

认证 Certificate

UL E243132
TUV B130780719003
CQC 13002088905
CQC 13002088906

KW热保护器-塑壳 KW THERMAL PROTECTOR-PLASTIC

1. 产品特性 PRODUCT CHARACTERISTICS

- 具有感应电流及感应温度而动作之双重性能
DUAL PERFORMANCE OF INDUCTION CURRENT AND INDUCTION TEMPERATURE
- 坚硬外壳支撑使保护内部元件不受浸漆和机械外力破坏
HARD SHELL SUPPORT PROTECTS INTERNAL COMPONENTS FROM PAINT IMPREGNATION AND MECHANICAL DAMAGE
- 精确的动作温度,不会出现动作蠕动现象
PRECISE ACTION TEMPERATURE, NO PERISTALSIS
- 每款零件均严格执行欧洲ROHS的环保标准。
EACH PART STRICTLY COMPLIES WITH THE ENVIRONMENTAL PROTECTION STANDARDS OF ROHS IN EUROPE.

2. 设计原理 DESIGN PRINCIPLE

KW型温度保护器是由条形高灵敏双金属元件、动触头、静触片、耐温导线等组成。工作时双金属元件固定在底板上,处于固定状态,动触头与静片闭合,电路导通。当使用电器因电流增大或周围温度DESIGN PRINCIPLE上升到该产品额定动作温度值时,双金属元件受热产生内应力而迅速动作,推动动触头,使触点断开,切断电源,电器停止工作,从而起到过热保护作用。当被保护电器温度下降到该产品的额定复位温度值时,双金属元件恢复到原状态动触点闭合,电器恢复工作,该产品具有电阻小,无噪声,抗震动,感温快,密封牢固,安全可靠等优点。

KW TYPE TEMPERATURE PROTECTOR IS COMPOSED OF STRIP HIGH SENSITIVE BIMETALLIC ELEMENTS, MOVING CONTACTS, STATIC CONTACTS, TEMPERATURE-RESISTANT CONDUCTORS, ETC. WHEN WORKING, THE BIMETALLIC ELEMENT IS FIXED ON THE BOTTOM PLATE, IN A FIXED STATE, THE MOVING CONTACT IS CLOSED WITH THE STATIC PIECE, AND THE CIRCUIT IS ON. WHEN THE ELECTRIC APPLIANCES ARE USED BECAUSE OF THE INCREASE OF CURRENT OR THE RISE OF AMBIENT TEMPERATURE TO THE RATED OPERATING TEMPERATURE OF THE PRODUCT, THE BIMETALLIC ELEMENTS ARE HEATED TO PRODUCE INTERNAL STRESS AND QUICKLY MOVE THE CONTACTS, SO THAT THE CONTACTS ARE DISCONNECTED, THE POWER SUPPLY IS CUT OFF, AND THE ELECTRICAL APPLIANCES STOP WORKING, THUS PLAYING THE ROLE OF OVERHEATING PROTECTION. WHEN THE TEMPERATURE OF THE PROTECTED ELECTRICAL APPLIANCES DROPS TO THE RATED RESET TEMPERATURE VALUE OF THE PRODUCT, THE BIMETALLIC ELEMENTS RETURN TO THE ORIGINAL STATE AND THE MOVABLE CONTACTS ARE CLOSED, AND THE ELECTRICAL APPLIANCES ARE RESTORED TO WORK. THE PRODUCT HAS THE ADVANTAGES OF SMALL RESISTANCE, NO NOISE, ANTI-VIBRATION, FAST TEMPERATURE SENSING, FIRM SEALING, SAFETY AND RELIABILITY.



3.应用范围 APPLICATION SCOPE

- 电机、马达、小家电MOTORS, MOTORS, SMALLHOUSEHOLD APPLIANCES
- 电池类产品BATTERY PRODUCTS
- 电子镇流器、照明灯具ELECTRONIC BALLASTS, LIGHTING FIXTURES
- 电热垫、电热毯ELECTRIC MAT AND BLANKET
- 过胶机、电动工具、充电器、变压器PASSING GLUE MACHINE, ELECTRIC TOOLS, CHARGER, TRANSFORMER

4.电气规格 ELECTRICAL SPECIFICATIONS

- 大塑壳: 8A/250V AC
- 小塑壳: 5A/250V AC

5.常用温度规格 COMMON TEMPERATURE SPECIFICATIONS

动作温度 Action temperature	复位温度 Reset temperature	动作温度 Action temperature	复位温度 Reset temperature
60 ± 5 °C	40 ± 15 °C	110 ± 5 °C	75 ± 15 °C
65 ± 5 °C	40 ± 15 °C	115 ± 5 °C	75 ± 15 °C
70 ± 5 °C	45 ± 15 °C	120 ± 5 °C	80 ± 15 °C
75 ± 5 °C	50 ± 15 °C	125 ± 5 °C	85 ± 15 °C
80 ± 5 °C	55 ± 15 °C	130 ± 5 °C	90 ± 15 °C
85 ± 5 °C	55 ± 15 °C	135 ± 5 °C	95 ± 15 °C
90 ± 5 °C	60 ± 15 °C	140 ± 5 °C	100 ± 15 °C
95 ± 5 °C	65 ± 15 °C	145 ± 5 °C	105 ± 15 °C
100 ± 5 °C	65 ± 15 °C	150 ± 5 °C	110 ± 15 °C
105 ± 5 °C	70 ± 15 °C	155 ± 5 °C	115 ± 15 °C

特殊规格可根据顾客要求制定 The special specification can also be manufactured as request

6.型号规格编码方法

CR-KW-XX °C

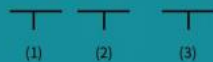

- (1) 代表塑壳
- (2) 代表产品系列代码
- (3) 代表产品温度

大塑壳尺寸图

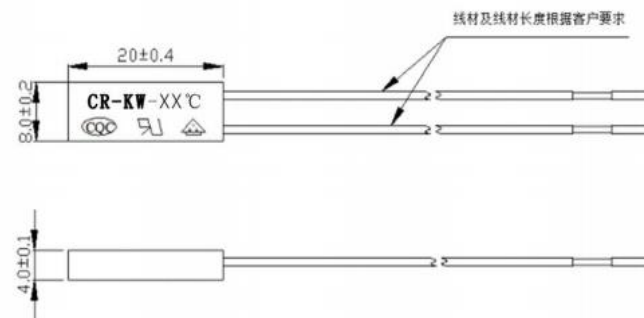

小塑壳尺寸图

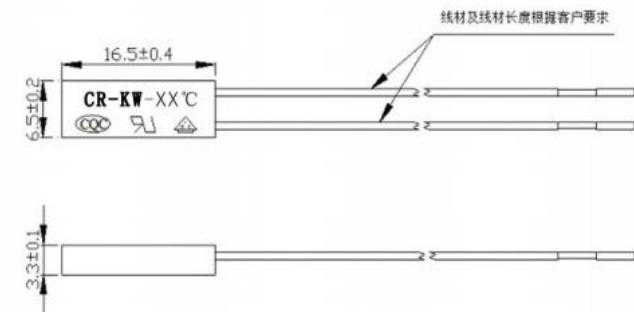



KW热保护器-铁壳 KW THERMAL PROTECTOR-IRON

1. 产品特性 PRODUCT CHARACTERISTICS

- 具有感应电流及感应温度而动作之双重性能
DUAL PERFORMANCE OF INDUCTION CURRENT AND INDUCTION TEMPERATURE
- 坚硬外壳支撑使保护内部元件不受浸漆和机械外力破坏
HARD SHELL SUPPORT PROTECTS INTERNAL COMPONENTS FROM PAINT IMPREGNATION AND MECHANICAL DAMAGE
- 精确的动作温度,不会出现动作蠕动现象
PRECISE ACTION TEMPERATURE, NO PERISTALSIS
- 每款零件均严格执行欧洲ROHS的环保标准。
EACH PART STRICTLY COMPLIES WITH THE ENVIRONMENTAL PROTECTION STANDARDS OF ROHS IN EUROPE.

2. 设计原理 DESIGN PRINCIPLE

KW型温度保护器是由条形高灵敏双金属元件、动触头、静触片、耐温导线等组成。工作时双金属元件固定在底板上,处于固定状态,动触头与静片闭合,电路导通。当使用电器因电流增大或周围温度DESIGN PRINCIPLE上升到该产品额定动作温度值时,双金属元件受热产生内应力而迅速动作,推开动触头,使触点断开,切断电源,电器停止工作,从而起到过热保护作用。当被保护电器温度下降到该产品的额定复位温度值时,双金属元件恢复到原状态动触点闭合,电器恢复工作,该产品具有电阻小,无噪声,抗震动,感温快,密封牢固,安全可靠等优点。

KW TYPE TEMPERATURE PROTECTOR IS COMPOSED OF STRIP HIGH SENSITIVE BIMETALLIC ELEMENTS, MOVING CONTACTS, STATIC CONTACTS, TEMPERATURE-RESISTANT CONDUCTORS, ETC. WHEN WORKING, THE BIMETALLIC ELEMENT IS FIXED ON THE BOTTOM PLATE, IN A FIXED STATE, THE MOVING CONTACT IS CLOSED WITH THE STATIC PIECE, AND THE CIRCUIT IS ON. WHEN THE ELECTRICAL APPLIANCES ARE USED BECAUSE OF THE INCREASE OF CURRENT OR THE RISE OF AMBIENT TEMPERATURE TO THE RATED OPERATING TEMPERATURE OF THE PRODUCT, THE BIMETALLIC ELEMENTS ARE HEATED TO PRODUCE INTERNAL STRESS AND QUICKLY MOVE THE CONTACTS, SO THAT THE CONTACTS ARE DISCONNECTED, THE POWER SUPPLY IS CUT OFF, AND THE ELECTRICAL APPLIANCES STOP WORKING, THUS PLAYING THE ROLE OF OVERHEATING PROTECTION. WHEN THE TEMPERATURE OF THE PROTECTED ELECTRICAL APPLIANCES DROPS TO THE RATED RESET TEMPERATURE VALUE OF THE PRODUCT, THE BIMETALLIC ELEMENTS RETURN TO THE ORIGINAL STATE AND THE MOVABLE CONTACTS ARE CLOSED, AND THE ELECTRICAL APPLIANCES ARE RESTORED TO WORK. THE PRODUCT HAS THE ADVANTAGES OF SMALL RESISTANCE, NO NOISE, ANTI-VIBRATION, FAST TEMPERATURE SENSING, FIRM SEALING, SAFETY AND RELIABILITY.

3.应用范围 APPLICATION SCOPE

- 电机、马达、小家电MOTORS, MOTORS, SMALLHOUSEHOLD APPLIANCES
- 电池类产品BATTERY PRODUCTS
- 电子镇流器、照明灯具ELECTRONIC BALLASTS, LIGHTING FIXTURES
- 电热垫、电热毯ELECTRIC MAT AND BLANKET
- 过胶机、电动工具、充电器、变压器PASSING GLUE MACHINE, ELECTRIC TOOLS, CHARGER, TRANSFORMER

4.电气规格 ELECTRICAL SPECIFICATIONS

- 大铁壳: 8A/250V AC
- 小铁壳: 5A/250V AC

5.常用温度规格 COMMON TEMPERATURE SPECIFICATIONS

动作温度 Action temperature	复位温度 Reset temperature	动作温度 Action temperature	复位温度 Reset temperature
60 ± 5 °C	40 ± 15 °C	110 ± 5 °C	75 ± 15 °C
65 ± 5 °C	40 ± 15 °C	115 ± 5 °C	75 ± 15 °C
70 ± 5 °C	45 ± 15 °C	120 ± 5 °C	80 ± 15 °C
75 ± 5 °C	50 ± 15 °C	125 ± 5 °C	85 ± 15 °C
80 ± 5 °C	55 ± 15 °C	130 ± 5 °C	90 ± 15 °C
85 ± 5 °C	55 ± 15 °C	135 ± 5 °C	95 ± 15 °C
90 ± 5 °C	60 ± 15 °C	140 ± 5 °C	100 ± 15 °C
95 ± 5 °C	65 ± 15 °C	145 ± 5 °C	105 ± 15 °C
100 ± 5 °C	65 ± 15 °C	150 ± 5 °C	110 ± 15 °C
105 ± 5 °C	70 ± 15 °C	155 ± 5 °C	115 ± 15 °C

特殊规格可根据客户要求制定 The special specification can also be manufactured as request

6.型号规格编码方法

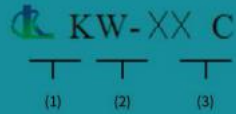

- (1) 代表铁壳
- (2) 代表产品系列代码
- (3) 代表产品温度

大铁壳尺寸图

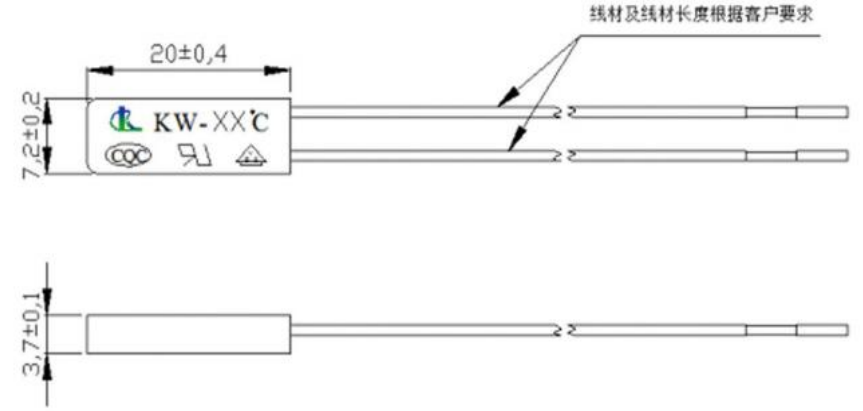

小铁壳尺寸图

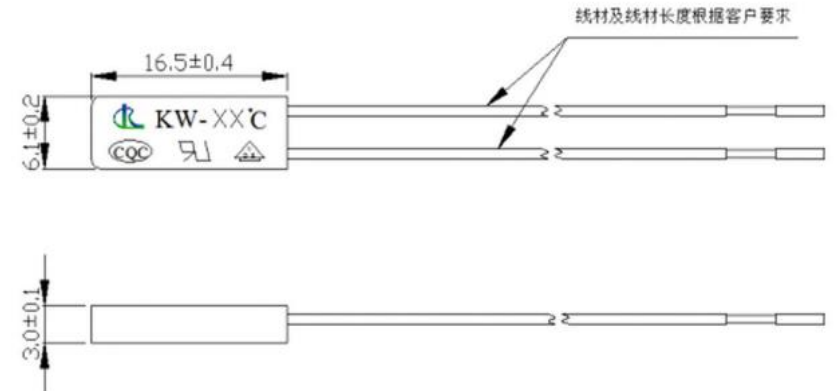

3

我们服务的客户



服务客户



4

企业环境（局部）



无尘车间



UL/TUV目击试验室证书

TÜVRheinland

Certificate of Appointment

No. UA 50448402-0001

The Applicant
Ningbo Xinyuan Electronic Co., Ltd.
Sanheng Road
Ningfengcun Industrial Park
Changhe Town, Cixi
Ningbo, Zhejiang 315326
P. R. China

has been authorized to carry out testing by the order
and under supervision of TÜV Rheinland
IEC 60691:2015, EN 60691:2016
IEC 60751:2008, EN 60751:2008

An audit of the laboratory was conducted according to ISO/IEC 17025
by a TÜV Rheinland auditor,
Audit Report No. 50298071-001
This certificate is valid until the next scheduled audit or up to 18 months,
at the discretion of TÜV Rheinland.

Date of issue: 27.09.2019

Certification body
Hao Jinhong

TÜV Rheinland(China) Co., Ltd.
Unit 707, AVIC Building, No.108, Central Road, East 3rd Ring Road,
Chaoyang District, Beijing China
Tel: 4008811300
Fax: +86 10 87006667 <http://www.tuv.cn>

TÜVRheinland

TÜV Rheinland (China) Ltd.

Certificate

or
Qualification

No. CL1108

Witness Test Level

For
Ningbo Xinyuan Electronic Co., Ltd.
Sanheng Road, Ningfengcun Industrial Park,
Changhe Town, Cixi, Ningbo, Zhejiang, 315326, P.R. China

Has been authorized to carry out testing by the order and under supervision of TÜV Rheinland.
It has successfully demonstrated capability to conduct measurement and to process test data
according to:
IEC 60691:2015, EN 60691:2016, IEC 60751:2008, EN 60751:2008
An assessment of the laboratory was conducted according to ISO/IEC 17025:2005 by a TÜV
Rheinland auditor.
Audit Report No. 15074259 005
This Certificate is valid to Aug. 01, 2019

TÜV Rheinland (China) Ltd.

Zhang Jie
Certifier

Kenny Shi
Department Manager



CERTIFICATE OF PARTICIPATION

Issued by
UL CCIC on behalf of
UL

Ningbo Xinyuan Electronics Co Ltd
Sanheng Rd, Ningfengcun Industrial Park
Changhe Town Cixi
Zhejiang 315326

has been assessed and found eligible to participate in
UL
WITNESS TEST DATA PROGRAM

Party Site Number: 1108214
UL-CCIC Company Limited

Issued: Sep 08, 2019
Expire: Sep 08, 2020

UL/TUV目击试验室(WTDP)



质量管理体系



认证证书

兹证明

宁波馨源电子有限公司

中国浙江省慈溪市长河镇宁丰村三横路 268-2 号 315326

经 NSF-ISR 评估，已建立的质量管理体系符合如下标准：

IATF 16949:2016

认证范围：

热熔断体的设计和制造

IATF 证书编号：0361353
证书编号：CNIATF040233
证书颁发日期：2019/11/07
注册日期：2019/10/31
到期日期*：2022/10/30

Tom Chestnut,
Sr Vice President - ISR,
NSF-ISR, Ltd.



NSF International Strategic Registrations

789 North Dixboro Road, Ann Arbor, Michigan 48105 | (888) NSF-9000 | www.nsf-isr.org

Authorized Registration and/or Accreditation Marks. This certificate is property of NSF-ISR and must be returned upon request.
*Company is audited for conformance at regular intervals. To verify registrations call (888) NSF-9000 or visit our web site at www.nsf-isr.org



质量管理体系认证证书

证书编号：19818Q1819R0M

统一社会信用代码/组织机构代码：91330282144814927P

兹证明：

宁波馨源电子有限公司

质量管理体系符合：GB/T19001-2016 idt ISO9001:2015

证书覆盖范围：**资质范围内热熔断体的生产和服务**

注册地址：慈溪市长河镇宁丰村

经营地址：浙江省慈溪市长河工业区三横路 2 号

首次发证日期：2018 年 09 月 06 日

本次发证日期：2018 年 09 月 06 日

证书有效日期：2021 年 09 月 05 日



中国认可
国际互认
管理体系
MANAGEMENT SYSTEM
CNAS C178-M



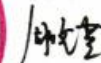

本证书在国家规定的各行政许可、资质许可有效期内使用有效
获证组织必须定期接受监督审核并经审核合格，方可保持证书有效性
证书有效性可通过新纪源网站www.xjyz.com查询或国家认监委网站www.cnca.gov.cn查询，也可通过扫描二维码查询



北京新纪源认证有限公司

地址：北京市朝阳区南湖东园122楼11层北区1201（邮编100102）

公司愿景

INSPIRATIONAL QUOTES



XYDZ



三元 SANYUAN

做优秀的民族企业

做强大的民族品牌

让世界爱上中国造

谢谢聆听

